

FERRI®



GROUP A

TM47

FARM

HYDRAULIC REACH MOWERS



HP 35 available to the rotor
HP 45 max to hydraulic motor



Floating head system



"Overlap" spiral rotor with two spiral rows



Drop forged brackets for the arms



Drop forged lever for flail head rotation



Oil cooler with thermostat (option)

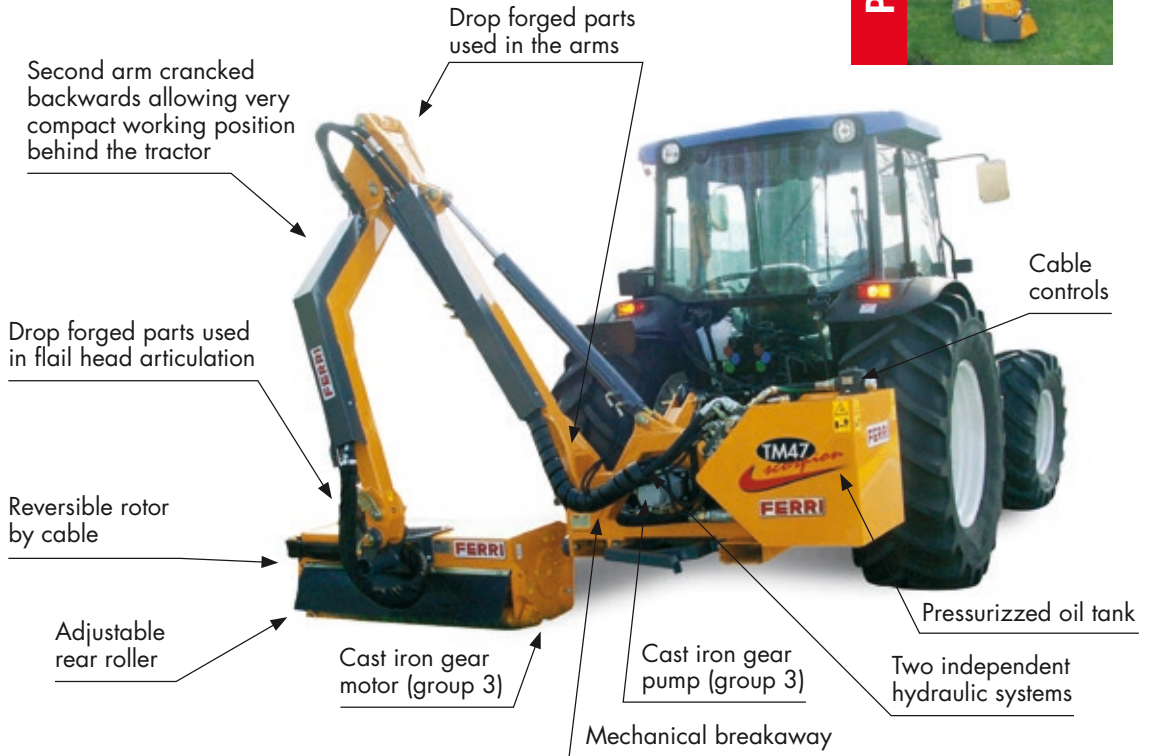

classic

Cable controls



electra

Monolever electric control



| HP Tractor | 50 | 60 | 70 | 80 | Min. tractor weight Kg | Min. tractor width m |
|------------|----|----|----|----|------------------------|----------------------|
| TM47 Farm | | | | | 2800 | 1,90 |

Working positions (m)

| | | TM47 Farm |
|---|---|-----------|
| A | m | 4,63 |
| B | m | 3,17 |
| C | m | 1,10 |
| D | m | 3,51 |
| E | m | 3,09 |
| F | m | 1,59 |
| G | m | 0,86 |
| H | m | 4,19 |

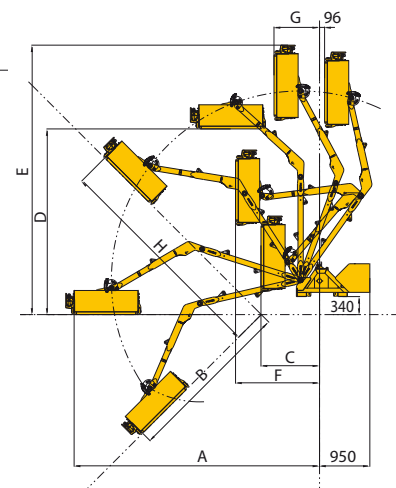

Technical data

| Model | Max horizontal reach* | Weight | Oil | Rotor | Pto | Flail head angle |
|-----------|-----------------------|--------|-----|-------|---------|------------------|
| | m | Kg | l | Rpm | MAX Rpm | |
| TM47 Farm | 4,63 | 839 | 125 | 3.100 | 540 | 230° |

* Reach measured from tractor centre line to head edge.

FERRI®



Machines with cable controls "Classic"

| Code | Model |
|---------------|--|
| TM47LHFD312JA | TM47 Farm with T1120 flail head m 1,20 - Multi-use blades |
| TM47LHFD312JH | TM47 Farm with T1120 flail head m 1,20 - Spoon blades |
| TM47LHFD312JT | TM47 Farm with T1120 flail head m 1,20 - "T" Hammer blades |

Machines with electric controls "Electra"

| Code | Model |
|---------------|--|
| TM47LHED312JA | TM47 Farm with T1120 flail head m 1,20 - Multi-use blades |
| TM47LHED312JH | TM47 Farm with T1120 flail head m 1,20 - Spoon blades |
| TM47LHED312JT | TM47 Farm with T1120 flail head m 1,20 - "T" Hammer blades |

Completing equipment to the base machine

| Code | Length | |
|--------------|-----------|---|
| TST5017 | (640-890) | 1 set of standard stabilizers to the tractor |
| OPT001121000 | | "Delta yoke" for stabilizers |
| TGA4611 | (640-890) | 1 set of bent stabilizers recommended with "Delta yoke" |
| TGA5014 | (340-460) | Top link stabilizer |

Option

| Code | |
|----------|----------------------------------|
| TM56SX02 | Oil cooler with thermostat |
| TM5606 | Lift float (LFA mechanic) |
| TM4601 | Bumpers with illumination system |

Flail head



| | T1120 |
|-------------------------|-------|
| Width (m) | 1,20 |
| Rotor speed (rpm) | 3100 |
| Blade tip speed (m/sec) | 60 |
| Flail head angle | 235° |
| Weight (Kg) | 210 |

T1 120
Direct drive



Flails T1 120

Interchangeable on the same rotor

| Multi-use blades for: grass, shrubs, bushes, sticks, wood | Spoon blade for: grass, shrubs, bushes, sticks, wood | "T" Hammer for woods |
|--|---|---|
| Ø max 3 cm | Ø max 2 cm | Ø max 4 cm |
|  |  |  |
| Cod. 0901146 | Cod. 0901164 | Cod. 0901147 |
| n° 44 | n° 22 | n° 22 |

Equipped with:

- Flail head
- Totally independent hydraulic system
- FLOATING head system
- Second arm cranked backwards allowing very compact working positions both on hedges and verges
- First arm double acting tap
- Drop forged parts used in the arms and flail head articulation
- Mechanical breakaway
- Reversible rotor
- Front and rear rubber resistant guard for flail head
- Oil and Pto shaft

Warning

IT IS RECOMMENDED that the connection between tractor and shredder and its setting up should be made with the Dealer according the instructions and warnings listed on our Use and Maintenance Manual. For further information please contact our after sales service.