

FERRI®

HP 52 available to the rotor
HP 68 max to hydraulic motor

TGA

PROFIT "PARALLELOGRAM" HYDRAULIC REACH MOWERS

GROUP A



Floating head system



"OVERLAP" spiral rotor with two spiral rows

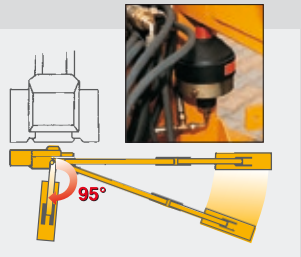

Hydraulic break-back with accumulator controlled autoreset facility



Drop forged parts



Oil cooler with thermostat

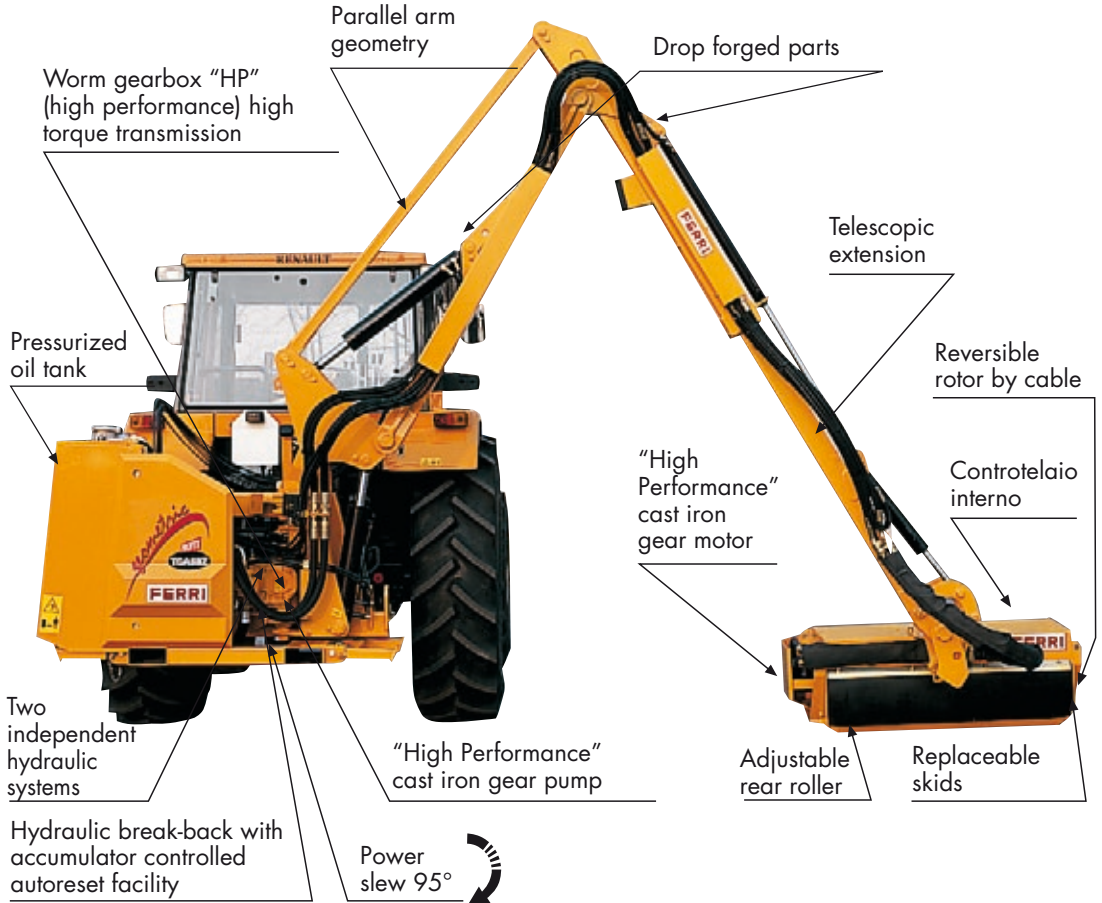

classic



Comandi Cable controls

comfort



Electro-Hydraulic proportional controls

HP Tractor 	80	90	100	110	Min. tractor weight Kg	Min. tractor width m
TGA58Z Profit					3600	2,30

Working positions (m)

		TGA58Z Profit
A	m	5,8
B	m	4,1
C	m	1,6
D	m	4,9
E	m	6,1
F	m	1,5
G	m	5,9

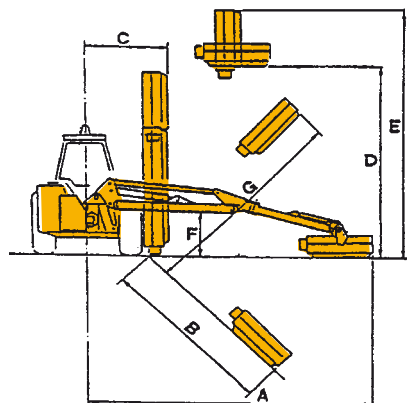

Technical data

Model	Max horizontal reach*	Weight	Telescopic extension	Oil	Rotor	P.d.f.	Flail head angle
	<i>m</i>	<i>Kg</i>	<i>m</i>	<i>l</i>	<i>Rpm</i>	<i>MAX Rpm</i>	
TGA58Z Profit	5,80	1.360	0,80	203	3.000	540	235°



Machines with cable controls "Classic"

Model with telescopic extension

TGA58Z Profit with flail head TN120 m 1,20

Machines with electro-hydraulic proportional controls "Comfort"

Model with telescopic extension

TGA58Z Profit Comfort with flail head TN120 m 1,20

Completing equipment to the base machine

WARNING: due to the high offset loads on the linkages it **is necessary** to fit two stabilizers

Stabilizers to the tractor (cod. TGA5020)

Fixed linkage to be adapted to the tractor top link area (cod. ATT/4)

Stabilizers for fixed linkage (cod. TGA5020)

Option

Lift float (cod. TGA5005)

Flail head





TN120

Width (m)	1,20
Rotor speed (rpm)	3000
Blade tip speed (m/sec)	60
Flail head angle	235°
Weight (Kg)	285



TN120
Direct drive

Flails TN120

Interchangeable on the same rotor		Interchangeable on the same rotor	
Multiuse and straight flails for: grass, bushes, shrubs, sticks, wood Ø max 4 cm	"T" Hammer blades for wood Ø max 5 cm	Articulated and straight flails for: grass, sticks, shrubs Ø max 2,5 cm	Hedge trimming blades for: grass, hedges Ø max 1 cm
			
Cod. 0901003 Cod. 0901148	Cod. 0901141	Cod. 0901068 Cod. 0901153	Cod. 0901139
n° 36 + 18	n° 18	n° 48 + 24	n° 24

Equipped with:

- Flail head
- Totally independent hydraulic system
- FLOATING head system
- Drop forged parts used in the arms and flail head articulation
- Worm gearbox "HP" (high performance) high torque transmission
- Oil cooler with thermostat
- Telescopic extension m 0,80
- Reversible rotor by cable
- Front and rear abrasion resistant guard for flail head
- Oil and pto shaft

Warning

IT IS RECOMMENDED that the connection between tractor and shredder and its setting up should be made with the Dealer according the instructions and warnings listed on our Use and Maintenance Manual. For further information please contact our after sales service.