

FERRI®



GROUP A

HP 35 available to the rotor
HP 45 max to hydraulic motor

T500G HYDRAULIC REACH MOWERS

SMART



Floating head system



Cast iron hydraulic rotor pump group 3



Boxed rotating bracket

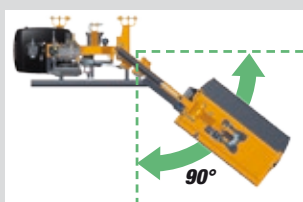

Hydraulic breakaway on power slew ram with max. relief valve (safeguards arm in case of obstacles)



Cable controls



Electric Proportional Controls with rotor start and stop by electric switch



HP Tractor		60	70	80	Min. tractor weight Kg	Min. tractor width m
T500G Smart Farm					2500	1,90



The polypropylene oil tank is separated from the frame and allows it to be isolated from any structural stress.
Fully recyclable.

Developed in collaboration with:



Working positions (m)

		T500G Smart Farm
A	m	5,00
B	m	3,06
C	m	1,46
D	m	3,62
E	m	4,84
F	m	2,15
G	m	1,69
H	m	4,77

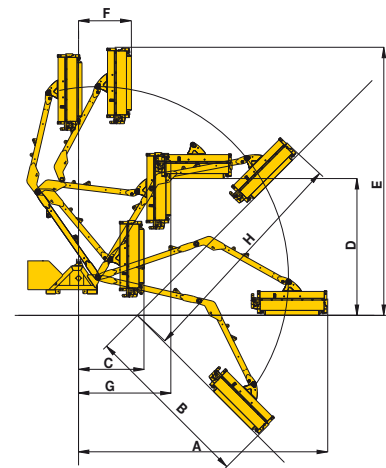

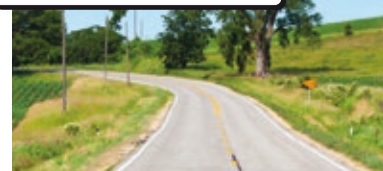

Technical data

Model	Max horizontal reach*	Weight	Oil	Rotor	Pto	Flail head angle
	<i>m</i>	<i>Kg</i>	<i>l</i>	<i>Rpm</i>	<i>MAX Rpm</i>	
T500G Smart Farm	5,00	860	120	3.100	540	235°

* Reach measured from tractor centre line to head edge.

Machines with cable controls "Classic"

Model

T500G Smart Farm with flail head TI120 m 1,20

Machines with electro-hydraulic proportional control "EP-Tronic"

Model

T500G Smart Farm EPTronic with flail head TI120 m 1,20

Completing equipment to the base machine

WARNING: due to the high offset loads on the linkages it **is necessary** to fit two stabilizers

Stabilizers to the tractor (cod. TST5017)

"Delta yoke" for stabilizers (cod. OPT001121000)

Stabilizers for "Delta yoke" (cod. TGA4611)

Option

Oil cooler with thermostat

Lift float (LFA mechanic)

Bumpers with illumination system (cod. TM46008)

Flail head

TI 120



Width (m)	1,20
Rotor speed (rpm)	3100
Blade tip speed (m/sec)	60
Flail head angle	235°
Weight (Kg)	210

TI 120



Flails TI 120

Interchangeable on the same rotor

Multi-use blades for: grass, shrubs, bushes, sticks, wood	Spoon blade for: grass, shrubs, bushes, sticks, wood	"T" Hammer for woods
Ø max 3 cm	Ø max 2 cm	Ø max 4 cm
		
Cod. 0901146	Cod. 0901164	Cod. 0901147
n° 44	n° 22	n° 22

Equipped with:

- Flail head
- Floating Head system
- The polypropylene oil tank, fully recyclable
- Boxed rotating bracket
- Hydraulic breakaway on power slew ram with max. relief valve (safeguards arm in case of obstacles)
- Mechanic roll-over protection system (SAB)
- Block valve on slew ram (better stability and safety in transfer)
- Totally Independent hydraulic system
- Cast iron hydraulic rotor pump group 3
- Cast iron hydraulic motor
- Reversible rotor by cable
- Front and rear abrasion resistant guard for flail head
- Oil and PTO shaft

Warning

IT IS RECOMMENDED that the connection between tractor and shredder and its setting up should be made with the Dealer according the instructions and warnings listed on our Use and Maintenance Manual. For further information please contact our after sales service.